

Surface Mount  **Power Splitter/Combiner**

SBTC-2-10X+

2 Way-0° 50Ω 5 to 1000 MHz

Features

- low insertion loss, 0.3 dB typ.
- excellent amplitude unbalance, 0. dB typ.
- very good phase unbalance, 1.0 deg. typ.
- temperature stable LTCC base
- small size
- low cost
- aqueous washable
- protected by US patent 6,963,255

Applications

- UHF/VHF receivers/transmitters
- cellular



Generic photo used for illustration purposes only

CASE STYLE: AT1667

+RoHS Compliant

The +Suffix identifies RoHS Compliance. See our web site for RoHS Compliance methodologies and qualifications

 Available Tape and Reel at no extra cost

| | |
|-----------|--------------|
| Reel Size | Devices/Reel |
| 13" | 500 |

Electrical Specifications

| Parameter | Frequency (MHz) | Min. | Typ. | Max. | Unit |
|-----------------------------|-----------------|------|------|------|--------|
| Frequency Range | | 5 | | 1000 | MHz |
| Insertion Loss Above 3.0 dB | 5 - 50 | — | 0.3 | 0.7 | dB |
| | 50 - 500 | — | 0.3 | 0.8 | |
| | 500 - 1000 | — | 0.5 | 1.4 | |
| Isolation | 5 - 50 | 20 | 29 | — | dB |
| | 50 - 500 | 18 | 25 | — | |
| | 500 - 1000 | 16 | 21 | — | |
| Phase Unbalance | 5 - 50 | — | — | 3 | Degree |
| | 50 - 500 | — | — | 3 | |
| | 500 - 1000 | — | — | 5 | |
| Amplitude Unbalance | 5 - 50 | — | — | 0.6 | dB |
| | 50 - 500 | — | — | 0.5 | |
| | 500 - 1000 | — | — | 0.5 | |

Maximum Ratings

| Parameter | Ratings |
|-----------------------------|----------------|
| Operating Temperature | -40°C to 85°C |
| Storage Temperature | -55°C to 100°C |
| Power Input (as a splitter) | 0.5W max. |
| Internal Dissipation | 0.125W max |

Permanent damage may occur if any of these limits are exceeded.

Pin Connections

| Function | Pin Number |
|----------|------------|
| SUM PORT | 6 |
| PORT 1 | 3 |
| PORT 2 | 4 |
| GROUND | 1,2 |
| NOT USED | 5 |

Product Marking

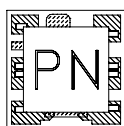

Electrical Schematic



Outline Drawing

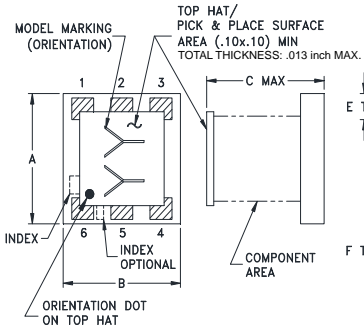

PCB Land Patter

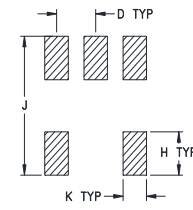

Suggested Layout,
Tolerance to be within ± 0.002

Outline Dimensions (inch mm)

| A | B | C | D | E | F |
|------|------|------|------|-------|------|
| .150 | .150 | .150 | .050 | .030 | .025 |
| 3.81 | 3.81 | 3.81 | 1.27 | 0.76 | 0.64 |
| G | H | J | K | wt | |
| .028 | .050 | .160 | .030 | grams | |
| 0.71 | 1.27 | 4.06 | 0.76 | 0.10 | |

Demo Board MCL P/N: TB-274 Suggested PCB Layout (PL-152)

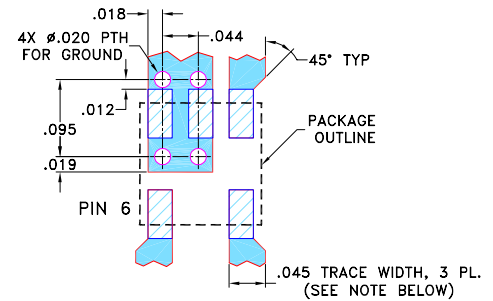

NOTE: 1. TRACE WIDTH IS SHOWN FOR ROGERS RO4350B WITH DIELECTRIC THICKNESS $0.020" \pm 0.0015"$; COPPER: 1/2 OZ. EACH SIDE. FOR OTHER MATERIALS TRACE WIDTH MAY NEED TO BE MODIFIED.
2. BOTTOM SIDE OF THE PCB IS CONTINUOUS GROUND PLANE.

- DENOTES PCB COPPER LAYOUT WITH SMOBC (SOLDER MASK OVER BARE COPPER)
- DENOTES COPPER LAND PATTERN FREE OF SOLDER MASK

Typical Performance Data

| Frequency (MHz) | Total Loss ¹ (dB) | | Amplitude Unbalance (dB) | Isolation (dB) | Phase Unbalance (deg.) | VSWR S | VSWR 1 | VSWR 2 |
|-----------------|------------------------------|------|--------------------------|----------------|------------------------|--------|--------|--------|
| | S-1 | S-2 | | | | | | |
| 5.00 | 3.25 | 3.12 | 0.13 | 30.21 | 0.41 | 1.03 | 1.17 | 1.14 |
| 7.00 | 3.24 | 3.11 | 0.13 | 31.41 | 0.32 | 1.02 | 1.16 | 1.12 |
| 10.00 | 3.26 | 3.13 | 0.13 | 32.34 | 0.13 | 1.02 | 1.15 | 1.12 |
| 50.00 | 3.26 | 3.15 | 0.12 | 31.93 | 0.06 | 1.02 | 1.14 | 1.11 |
| 70.00 | 3.28 | 3.16 | 0.12 | 31.37 | 0.07 | 1.03 | 1.14 | 1.11 |
| 100.00 | 3.29 | 3.18 | 0.11 | 30.43 | 0.12 | 1.03 | 1.13 | 1.10 |
| 200.00 | 3.34 | 3.24 | 0.10 | 28.05 | 0.20 | 1.05 | 1.12 | 1.10 |
| 300.00 | 3.38 | 3.30 | 0.08 | 26.00 | 0.24 | 1.06 | 1.11 | 1.09 |
| 400.00 | 3.39 | 3.34 | 0.05 | 24.32 | 0.26 | 1.07 | 1.09 | 1.08 |
| 500.00 | 3.45 | 3.44 | 0.02 | 23.24 | 0.28 | 1.08 | 1.07 | 1.07 |
| 600.00 | 3.48 | 3.50 | 0.02 | 21.78 | 0.28 | 1.10 | 1.05 | 1.06 |
| 700.00 | 3.45 | 3.52 | 0.07 | 21.08 | 0.21 | 1.10 | 1.02 | 1.05 |
| 800.00 | 3.47 | 3.59 | 0.12 | 20.74 | 0.09 | 1.09 | 1.03 | 1.06 |
| 900.00 | 3.49 | 3.67 | 0.18 | 20.62 | 0.06 | 1.08 | 1.06 | 1.08 |
| 1000.00 | 3.52 | 3.76 | 0.24 | 20.71 | 0.27 | 1.06 | 1.10 | 1.11 |

1. Total Loss = Insertion Loss + 3dB splitter loss.

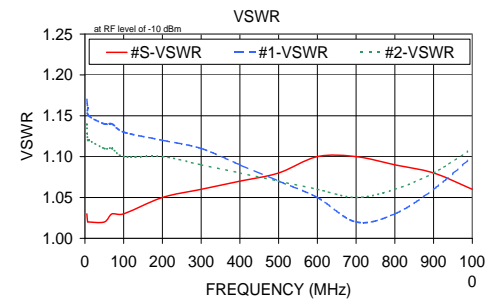
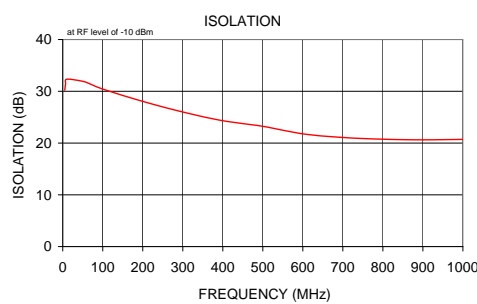
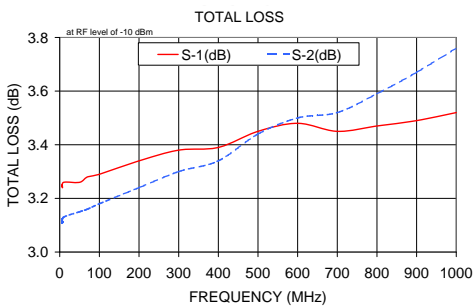

Additional Notes

- Performance and quality attributes and conditions not expressly stated in this specification document are intended to be excluded and do not form a part of this specification document.
- Electrical specifications and performance data contained in this specification document are based on Mini-Circuit's applicable established test performance criteria and measurement instructions.
- The parts covered by this specification document are subject to Mini-Circuits standard limited warranty and terms and conditions (collectively, "Standard Terms"); Purchasers of this part are entitled to the rights and benefits contained therein. For a full statement of the Standard Terms and the exclusive rights and remedies thereunder, please visit Mini-Circuits' website at www.minicircuits.com/MCLStore/terms.jsp